

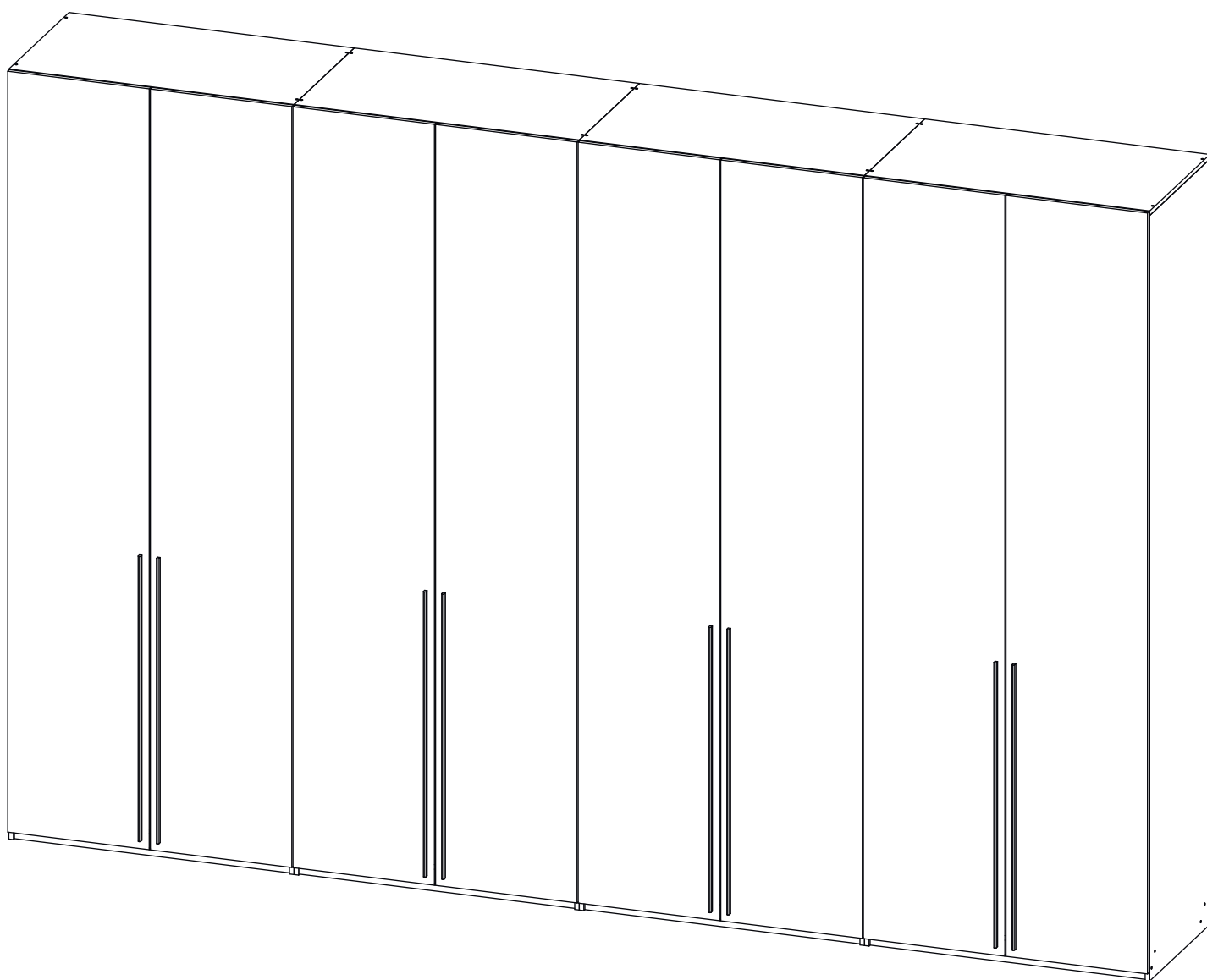





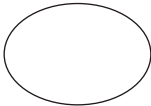
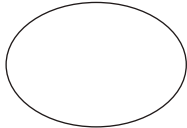

# Инструкция по сборке типовая

## Хейсон - 19

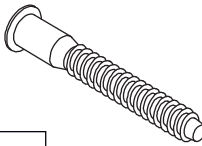
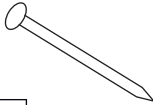

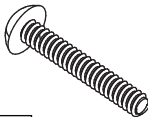
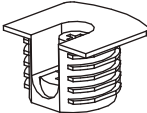
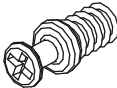
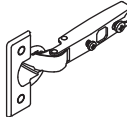
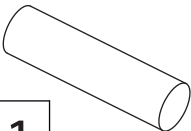

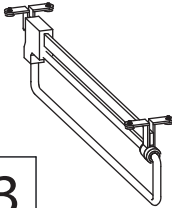
# Фурнитура

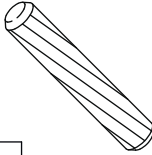
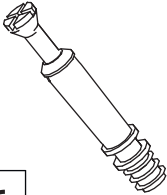
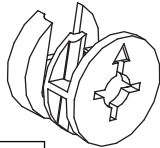
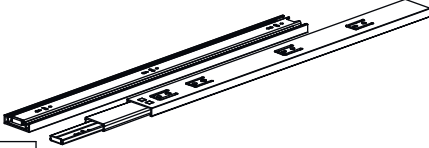
				
21	22	23	24	25
<u>Заглушка</u> Ø13	<u>Заглушка</u> Ø17-20	Ручка	<u>Евровинт 7x50</u>	<u>Гвоздь 1,6x25</u>
				
26	27	28	29	30
<u>Саморез 3,5x16</u>	<u>Винт для ручки</u> M4x23	<u>Стяжка VB35</u>	<u>Винт для стяжки</u> VB35	<u>Петля накладная</u>
				
31	32	33	34	35
<u>Штанга</u>	<u>Штангодержатель</u>	<u>Штанга</u> <u>выдвижная</u>	<u>Евровинт 6,3x13</u>	<u>Шкант бук</u>
				
36	37	38		
<u>Шток эксцентрика</u>	<u>Эксцентрик</u>	<u>Шариковые направляющие</u>		

При глубине меньше 500мм устанавливается выдвижная штанга.

# 1

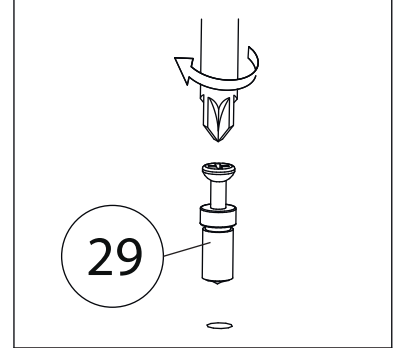
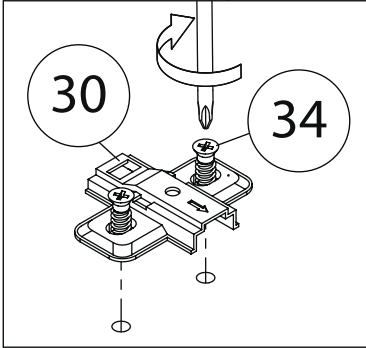
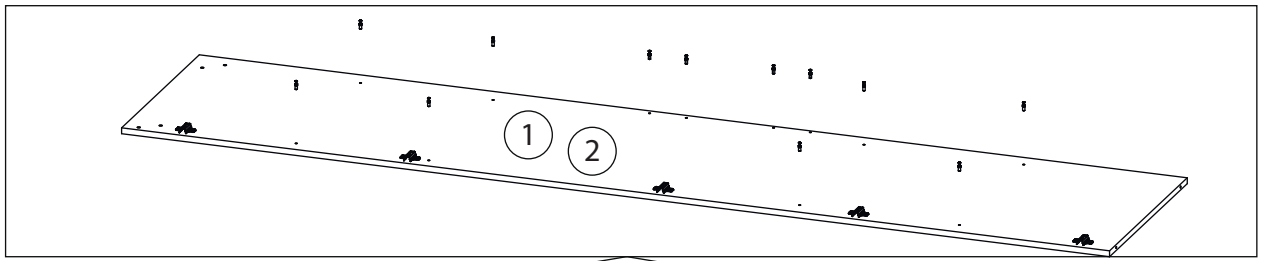

# 2

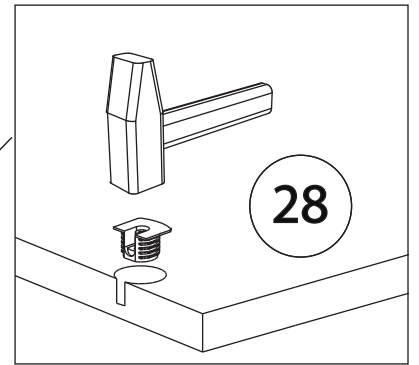
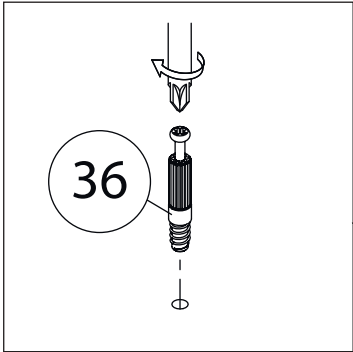
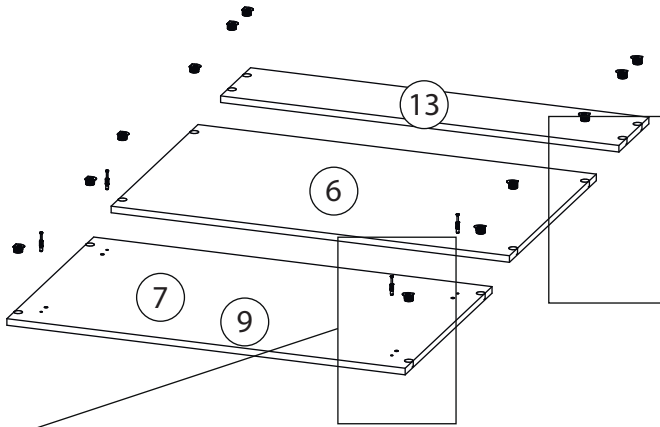

# 3

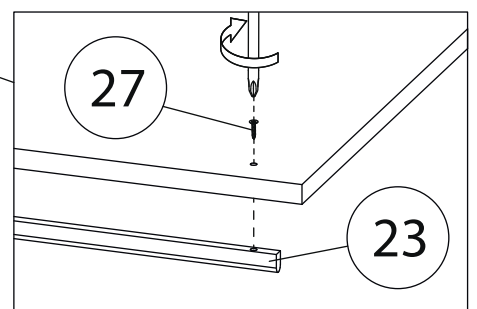
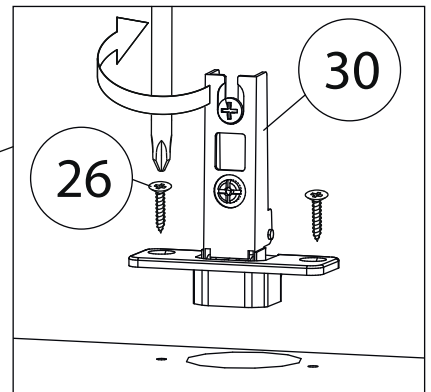
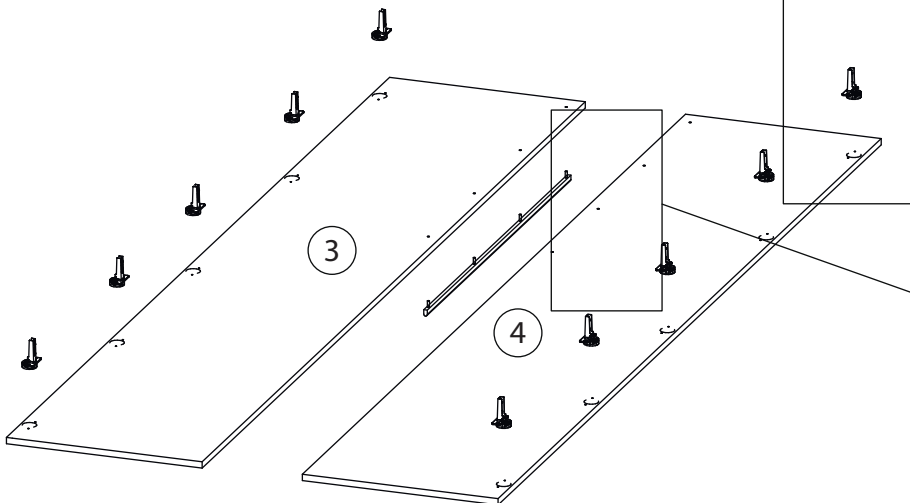

# 4

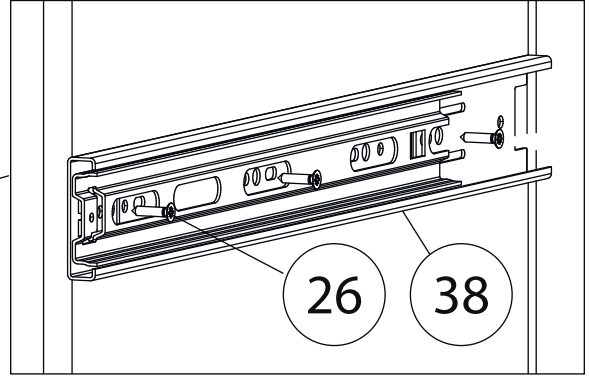
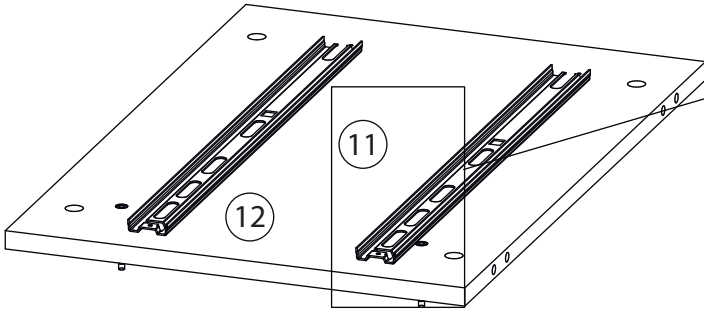

# 5

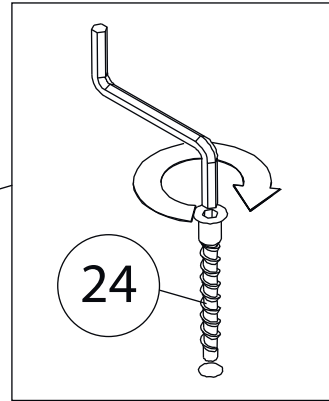
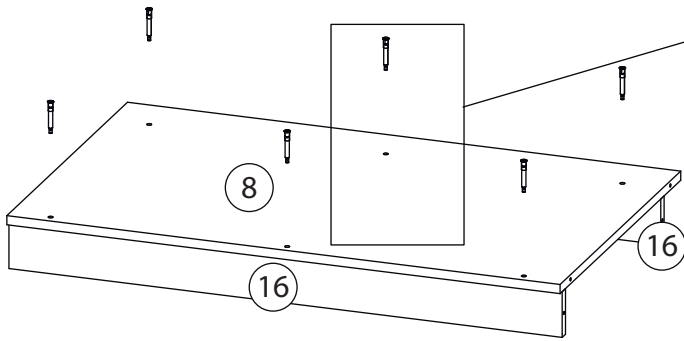

# 6

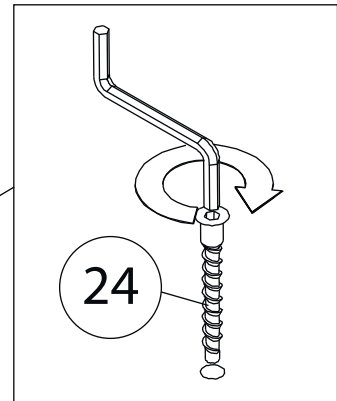
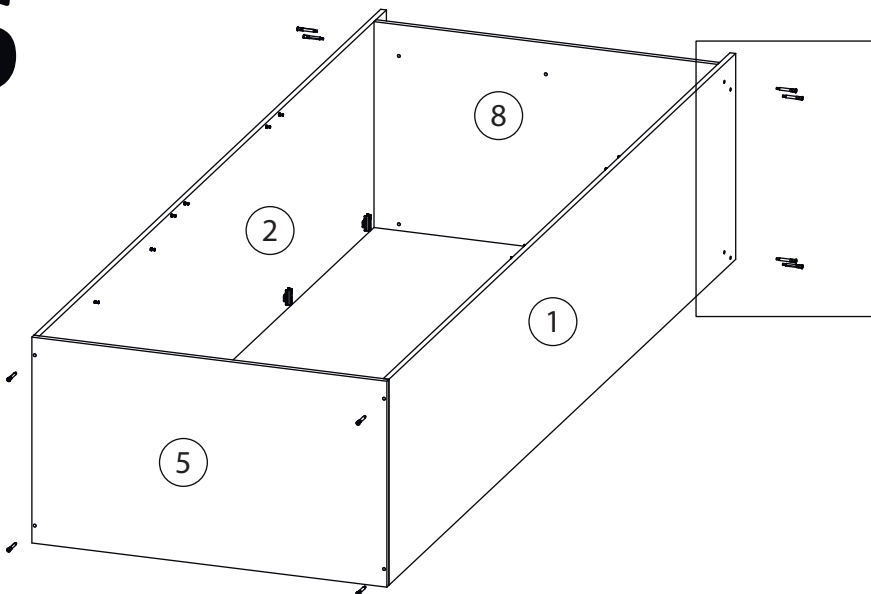

# 7

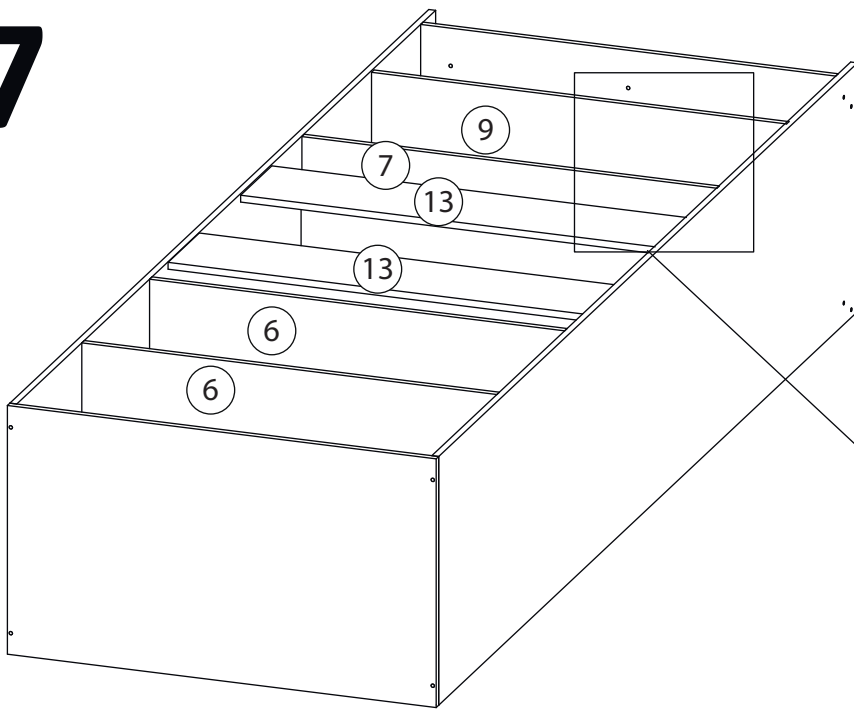

# 8

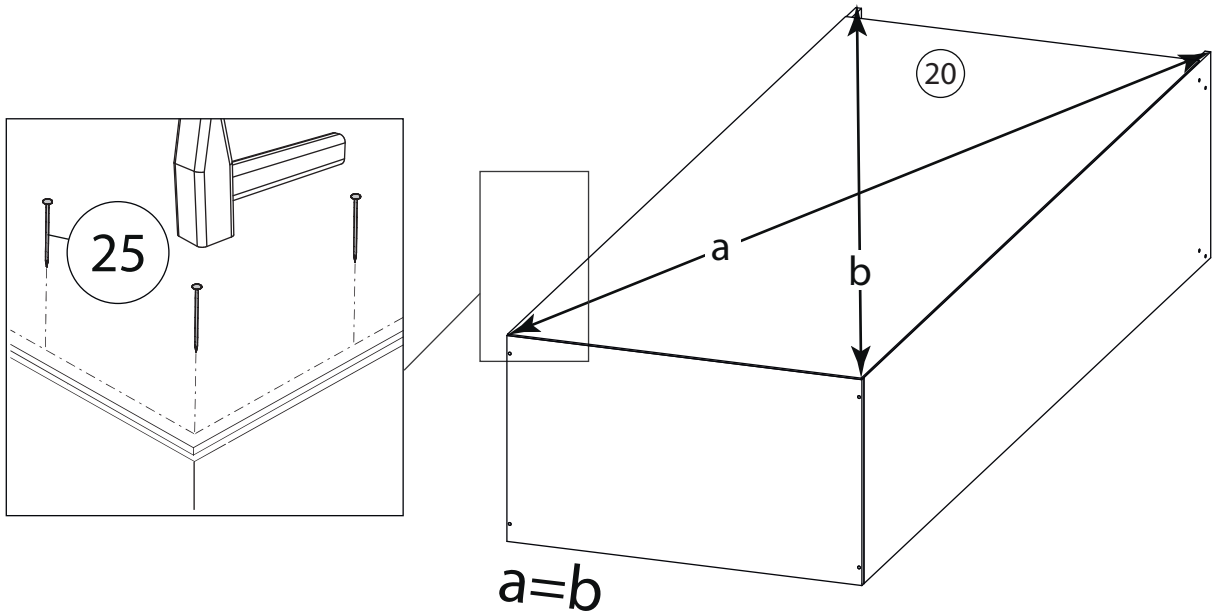

# 9

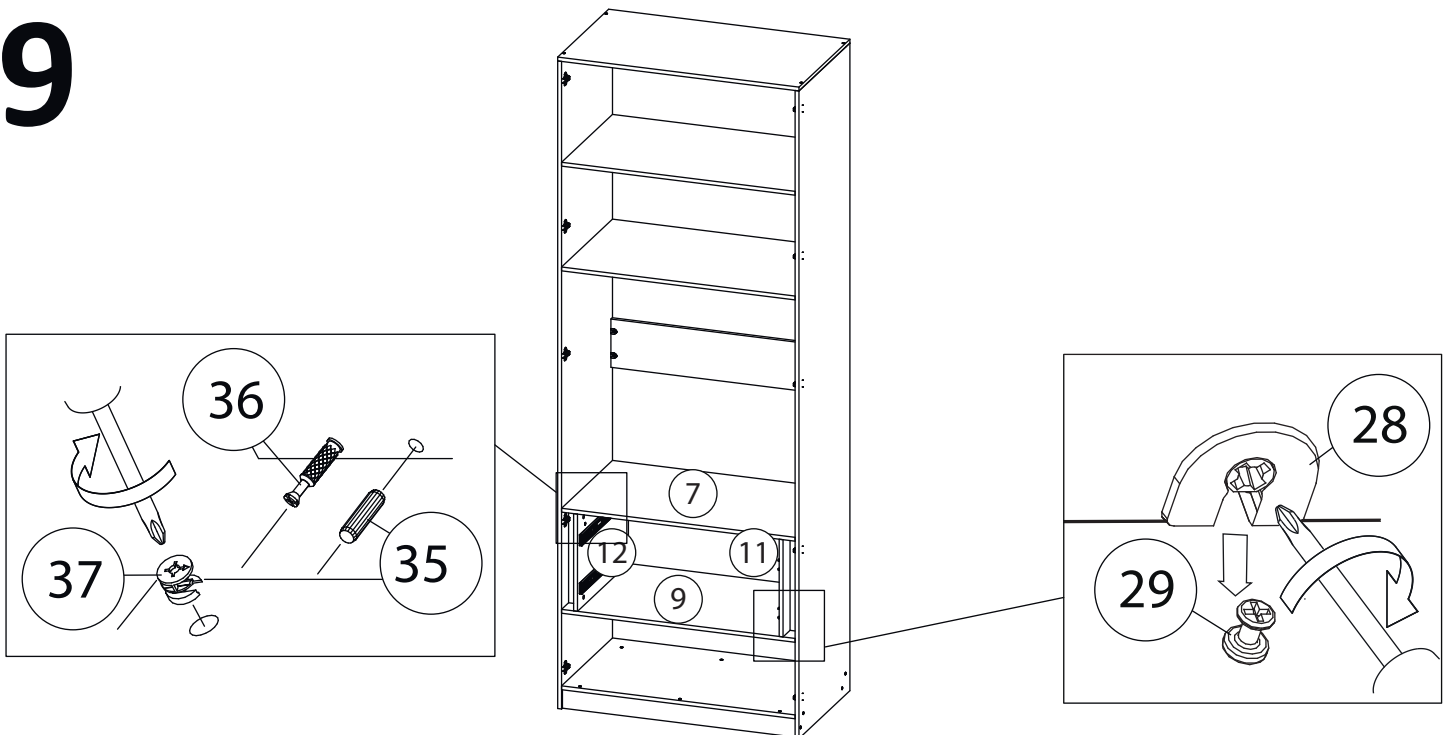

# 10

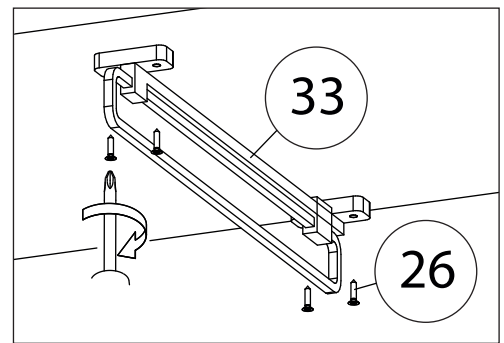
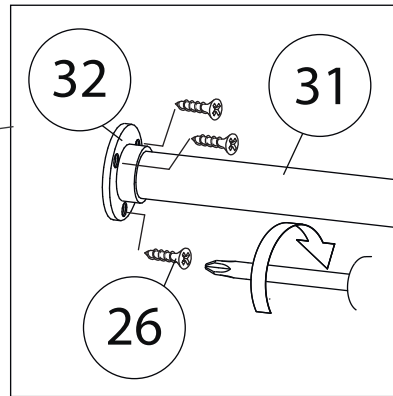
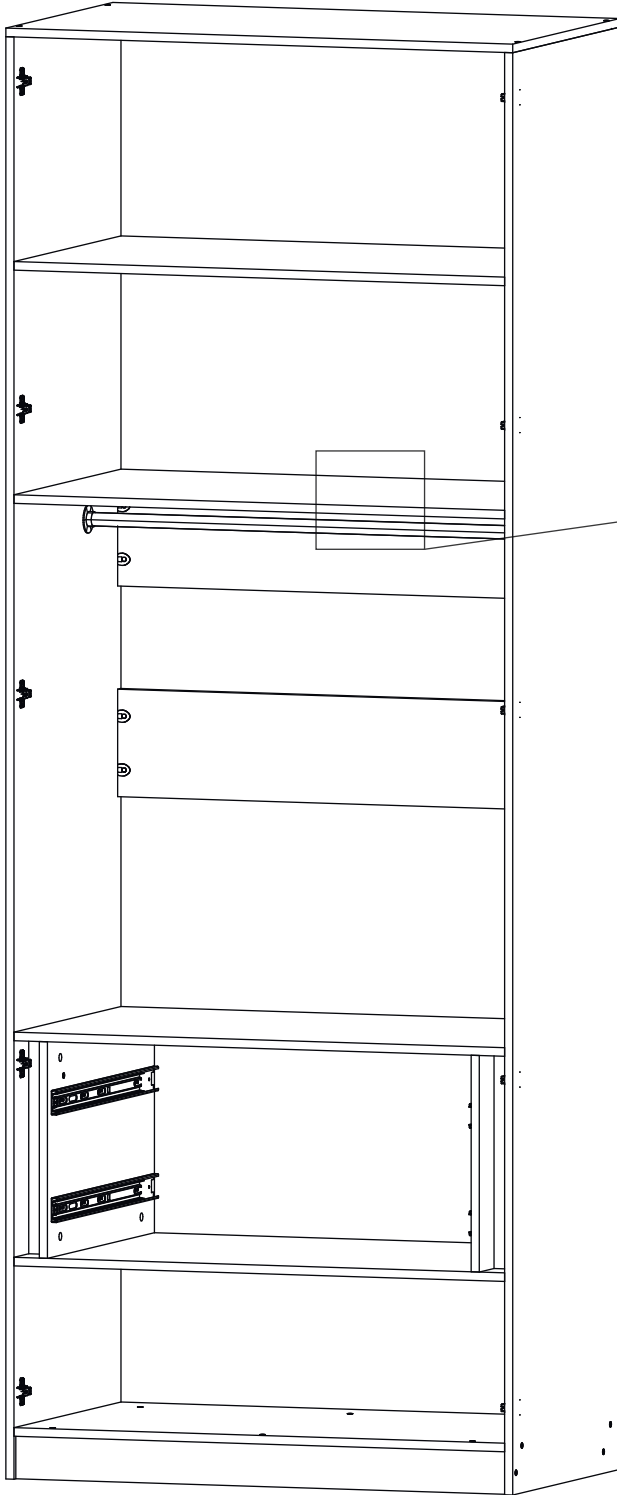

# 11

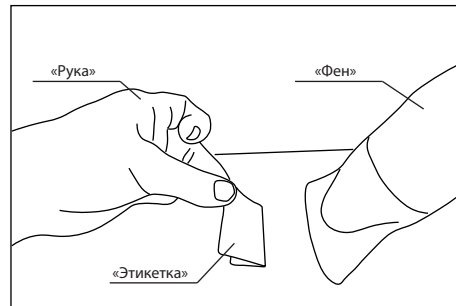
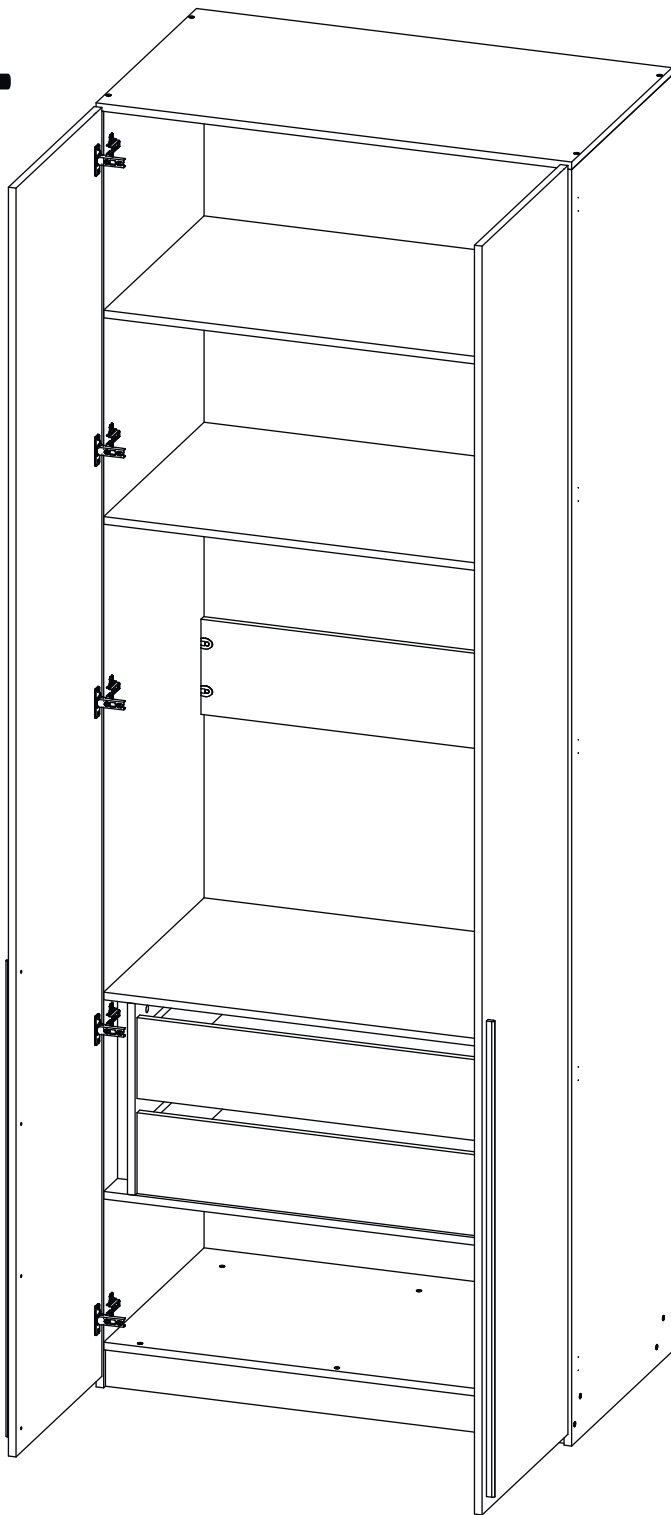

Удалить с детали этикетки со штрихкодом при помощи фена.



Заклеить технические отверстия заглушками.

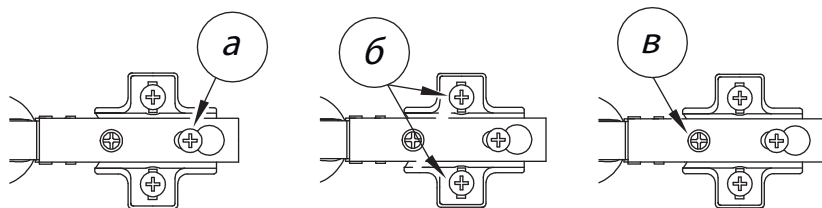

## Регулировка петель

а - регулировка расстояния между дверью и корпусом  
б - регулировка положения двери по-вертикали  
в - регулировка положения ТТдвери по-горизонтالي